

# CNCmakers Limited

Address: No.168, Xiadu Road, Haizhu District, Guangzhou, China 510300

Email: [info@CNCmakers.com](mailto:info@CNCmakers.com)

Website: [www.CNCmakers.com](http://www.CNCmakers.com)

Tel: +86-138-24444158

Fax: +86-20-84185336

## JLD6 6-STATION TOOL POST

### JLD6 series Tool post (Turret)

JLD6 series horizontal electric tool post adopts the working principle of worm wheel and worm driver, front and rear fluted disc locking, it features dependable and steady transposition, short time of changing position, big tangential torque, multi-position tool carrier. The transposition and transmitting adopt dependable contactless hall component with long service life, The series tool post is an ideal product to process complicated parts.

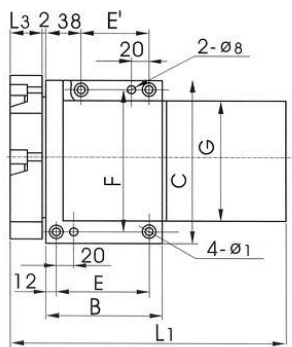

A 向  
JLD6-C0625~C6125

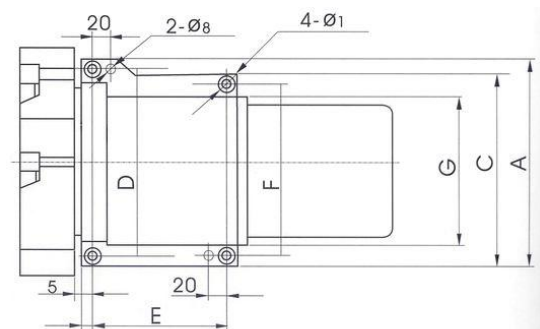
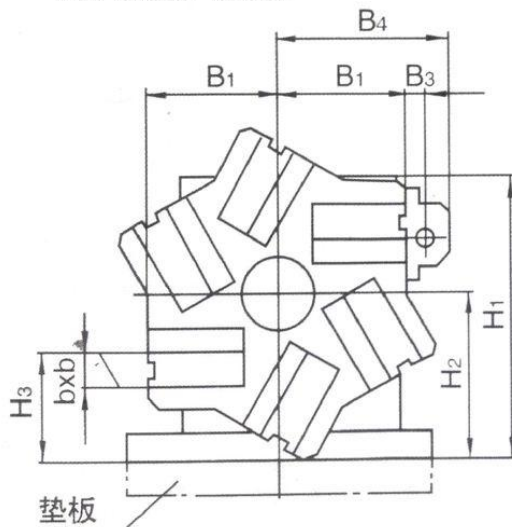
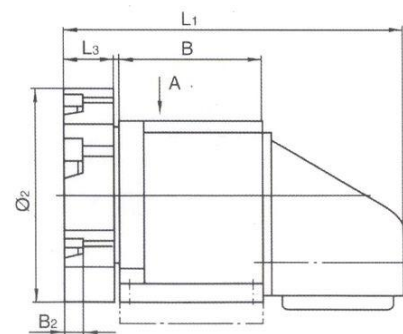

A 向  
JLD6-C6132~C6150

### Installation dimension

size model	H1	H2	H3	L1	L3	B1	B2	B3	B4	A	B	C	D	E	E'	F	G	φ1	φ2	b
JLD6-0625	172	100	59	315	35	63	14	15	93	/	133	164	/	106	80	144	120	11	190	14
JLD6-6132	200	118	78	380	55	92	20	25	142	222	160	207	200	140	/	183	155	11	240	20
JLD6-6140	200	118	78	380	55	92	20	25	142	222	160	207	200	140	/	183	155	11	240	25

### Technical Specifications

model	Spec.	Motor Power(w)	Motor Speed(rpm)	Clamp Torque(KN)	Re-positioning Accuracy(°)	Tool Change Time(s)			
						60°	120°	180°	240°
JLD6-0625		60	1400	12	±2	1.5	2	2.5	3
JLD6-6132		120	1400	20	±2	1.5	2	2.5	3
JLD6-6140		120	1400	20	±2	1.5	2	2.5	3

[User Guide](#)

[Diagram](#)

[Production Line](#)