

CNCmakers Limited

Address: No.168, Xiadu Road, Haizhu District, Guangzhou, China 510300

Email: info@CNCmakers.com

Website: www.CNCmakers.com

Tel: +86-138-24444158

Fax: +86-20-84185336

SJT SERIES AC SERVO MOTOR

Motor Model Significance

Example: 80SJT-MZ032E (A4Y1X)

80 SJT - M Z 032 E (A□ Y□ X)

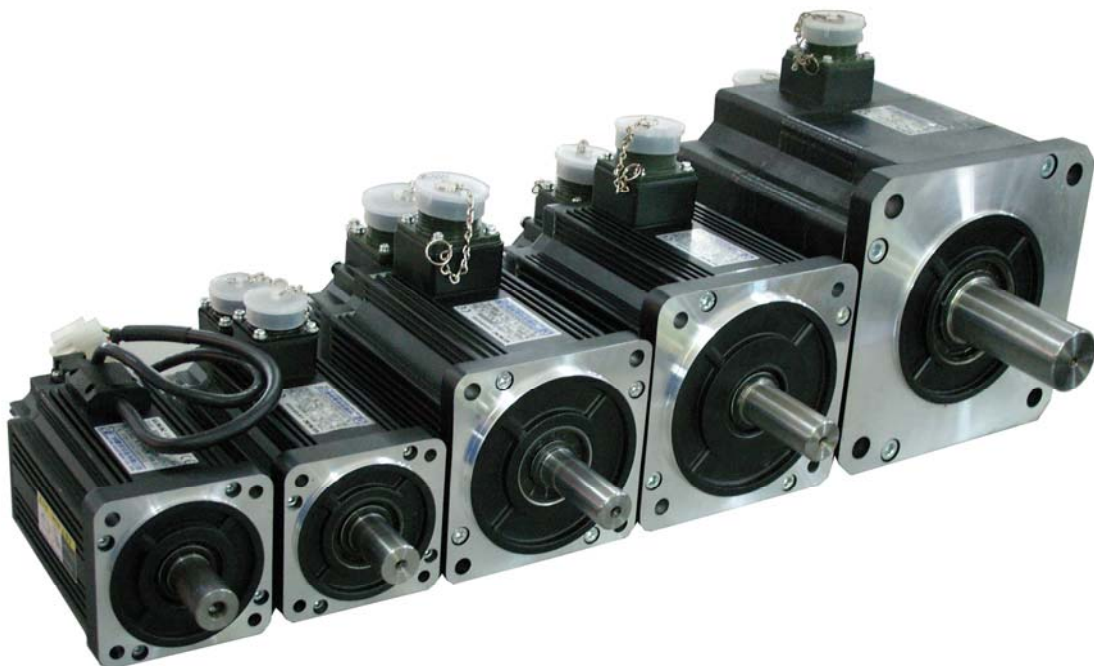
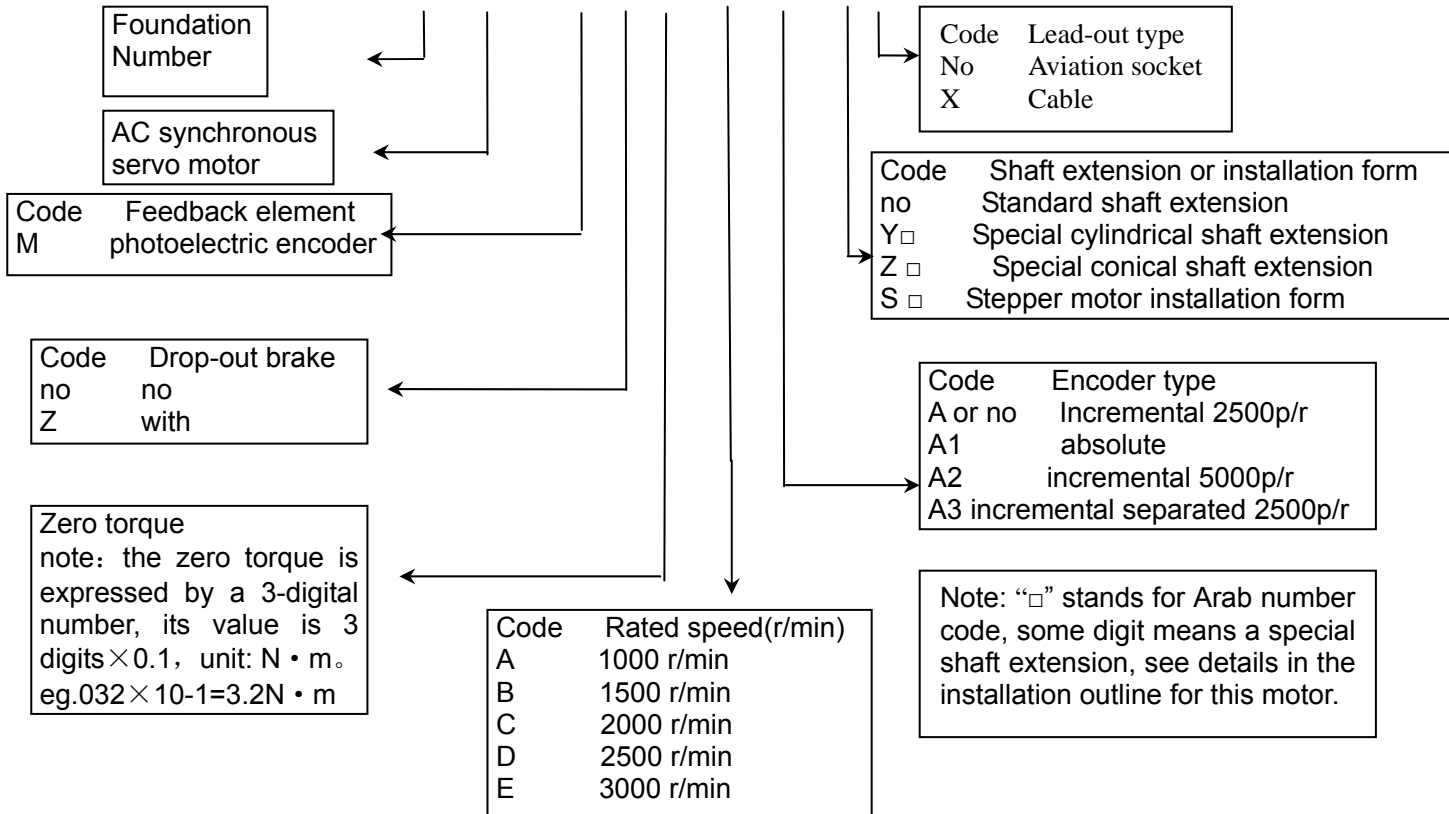

CNCmakers Limited

Address: No.168, Xiadu Road, Haizhu District, Guangzhou, China 510300

Email: info@CNCmakers.com Website: www.CNCmakers.com Tel: +86-138-24444158 Fax: +86-20-84185336

Product Feature

- Optimizing design, compact, beautiful contour, long-term continuous working in rated working mode;
- High performance rare earth permanent magnet material, high power, large load;
- Excellent reverse potential sine, sine wave current drive and excellent low speed performance;
- Motor inertia meeting machine feed drive;
- F level insulation material to extend motor life;
- Imported feedback components, original imported low-noise motor bearing to reduce vibration and noise;
- Full airproof and high reliability to meet industry environment;
- Optimum matching with our AC servo drive unit to realize optimum servo performance.

80SJT SERIES MOTOR TECHNICAL PARAMETERS

Item \ Type	80SJT-M024C	80SJT-M024E	80SJT-M032C	80SJT-M032E
Rated power (kW)	0.5	0.75	0.66	1.0
Pole pairs	4			
Drive unit input voltage (V)	3-phase (or single phase) AC 220V			3-phase AC 220V
Rated current (A)	3	4.8	5	6.2
Zero torque (N·m)	2.4	2.4	3.2	3.2
Rated torque (N·m)	2.4	2.4	3.2	3.2
Max. torque (N·m)	7.2	7.2	9.6	9.6
Rated speed (r/min)	2000	3000	2000	3000
Max. speed (r/min)	2500	4000	2500	4000
Moment inertia (kg·m ²)	0.83×10 ⁻⁴	0.83×10 ⁻⁴	1.23×10 ⁻⁴	1.23×10 ⁻⁴
Weight (kg)	2.8	2.9	3.4	3.5
Insulation degree	F			
Vibration degree	R			
Protection degree	IP65			
Installation type	IMB5 (flange)			
Working mode	S1 (continuous)			
Imbedded encoder (p/r)	Incremental 2500 p/r (standard configuration)			
Brake	None			

CNCmakers Limited

Address: No.168, Xiadu Road, Haizhu District, Guangzhou, China 510300

Email: info@CNCmakers.com Website: www.CNCmakers.com Tel: +86-138-24444158 Fax: +86-20-84185336

110SJ SERIES, 130SJ SERIES MOTOR TECHNICAL PARAMETERS (1)

Item \ Type	110SJT-M 040D	110SJT-M 060D	130SJT-M 040D	130SJT-M 050D	130SJT-M 060D
Rated power (kW)	1.0	1.5	1.0	1.3	1.5
Pole pairs	4				
Drive unit input voltage (V)	3-phase (or single phase) AC 220V	3-phase AC 220V			
Rated current (A)	4.5	7	4	5	6
Zero torque (N·m)	4	6	4	5	6
Rated torque (N·m)	4	6	4	5	6
Max. torque (N·m)	12	12	10	12.5	18
Rated speed (r/min)	2500	2500	2500	2500	2500
Max. speed (r/min)	3000	3000	3000	3000	3000
Moment inertia (kg·m ²)	0.68×10 ⁻³	0.95×10 ⁻³	1.1×10 ⁻³	1.1×10 ⁻³	1.3×10 ⁻³
Weight (kg)	6.1	7.9	6.5	6.5	7.2
Insulation degree	B				
Vibration degree	R				
Protection degree	IP65				
Installation type	IMB5 (flange)				
Working mode	S1 (continuous)				
Imbedded encoder (p/r)	Incremental 2500 p/r (standard configuration)				
Brake	DC 24V,4N·m, 1.6kg is added to the corresponding motor		DC 24V,12N·m, 2.9kg is added to the corresponding motor		

110SJ SERIES, 130SJ SERIES MOTOR TECHNICAL PARAMETERS (2)

Item \ Type	130SJT-M 075D	130SJT-M 100B	130SJT-M 100D	130SJT-M 150B	130SJT-M 150D
Rated power (kW)	1.88	1.5	2.5	2.3	3.9
Pole pairs	4				
Drive unit input voltage (V)	3-phase AC 220V				
Rated current (A)	7.5	6	10	8.5	14.5
Zero torque (N·m)	7.5	10	10	15	15
Rated torque (N·m)	7.5	10	10	15	15
Max. torque (N·m)	20	25	25	30	30
Rated speed (r/min)	2500	1500	2500	1500	2500
Max. speed (r/min)	3000	2000	3000	2000	3000
Moment inertia (kg·m ²)	1.85×10 ⁻³	2.42×10 ⁻³	2.42×10 ⁻³	3.1×10 ⁻³	3.6×10 ⁻³
Weight (kg)	8.1	9.6	9.7	11.9	12.7
Insulation degree	B				
Vibration degree	R				
Protection degree	IP65				
Installation type	IMB5 (flange)				
Working mode	S1 (continuous)				
Imbedded encoder (p/r)	Incremental 2500 p/r (standard configuration)				
Brake	DC 24V,12N·m, 2.9kg is added to the corresponding motor				

CNCmakers Limited

Address: No.168, Xiadu Road, Haizhu District, Guangzhou, China 510300

Email: info@CNCmakers.com

Website: www.CNCmakers.com

Tel: +86-138-24444158

Fax: +86-20-84185336

175SJT SERIES MOTOR TECHNICAL PARAMETERS

Item \ Type	175SJT-M 180B	175SJT-M 180D	175SJT-M 220B	175SJT-M 220D	175SJT-M 300B	175SJT-M 300D
Rated power (kW)	2.8	3.8	3.5	4.5	3.8	6
Pole pairs	3					
Drive unit input voltage (V)	3-phase AC 220V					
Rated current (A)	15	16.5	17.5	19	19	27.5
Zero torque (N·m)	18	18	22	22	30	30
Rated torque (N·m)	18	14.5	22	17.6	24	24
Max. torque (N·m)	36	29	44	35.2	48	48
Rated speed (r/min)	1500	2500	1500	2500	1500	2500
Max. speed (r/min)	2000	3000	2000	3000	2000	3000
Moment inertia (kg·m ²)	6.5×10^{-3}	6.5×10^{-3}	9.0×10^{-3}	9.0×10^{-3}	11.2×10^{-3}	11.2×10^{-3}
Weight (kg)	22.8	22.9	28.9	29.2	34.3	34.3
Insulation degree	B					
Vibration degree	R					
Protection degree	IP65					
Installation type	IMB5 (flange)					
Working mode	S1 (continuous)					
Imbedded encoder	Incremental 2500 p/r (standard configuration)					
Brake	DC 24V, 32N·m, 7.7kg is added to the corresponding motor					

80SJT SERIES MOTOR OUTLINE DIMENSION:

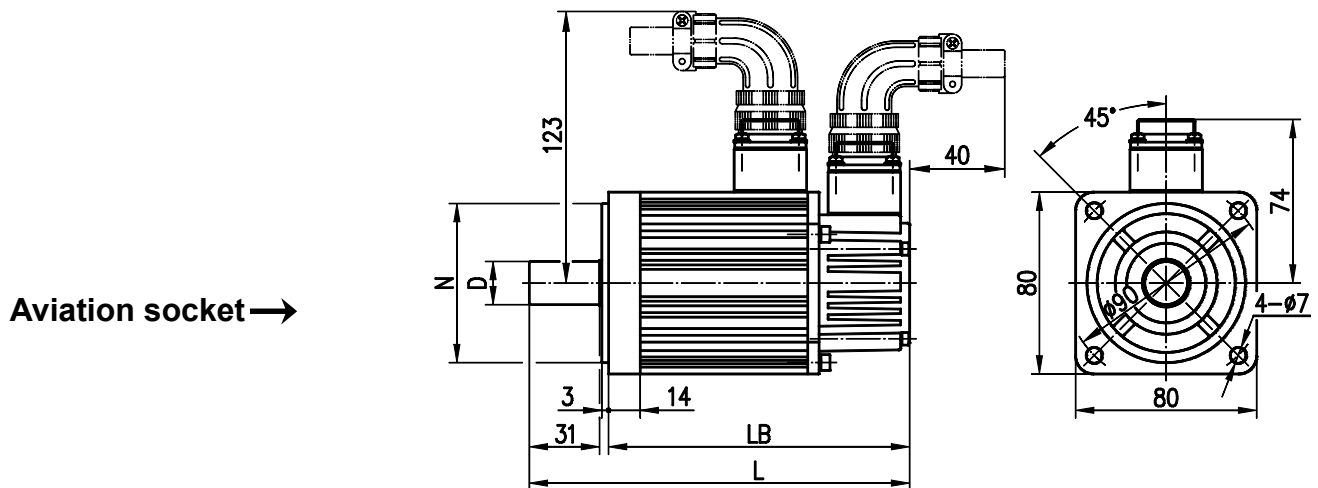

CNCmakers Limited

Address: No.168, Xiadu Road, Haizhu District, Guangzhou, China 510300

Email: info@CNCmakers.com

Website: www.CNCmakers.com

Tel: +86-138-24444158

Fax: +86-20-84185336

Cable socket →

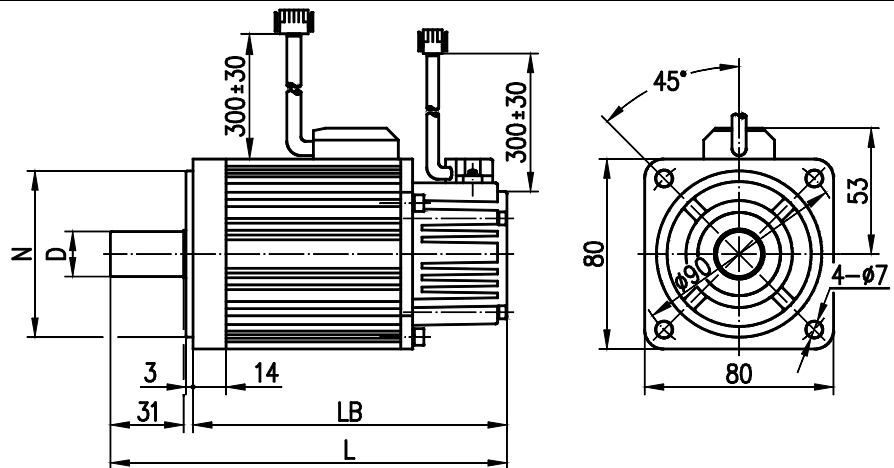

type	D(mm)	N(mm)	LB(mm)	L(mm)
80SJT-M024C	$\phi 19^{0}_{-0.013}$	$\phi 70^{0}_{-0.03}$	163	198
80SJT-M024E	$\phi 19^{0}_{-0.013}$	$\phi 70^{0}_{-0.03}$	163	198
80SJT-M032C	$\phi 19^{0}_{-0.013}$	$\phi 70^{0}_{-0.03}$	181	216
80SJT-M032E	$\phi 19^{0}_{-0.013}$	$\phi 70^{0}_{-0.03}$	181	216

110 SJT SERIES MOTOR OUTLINE DIMENSION

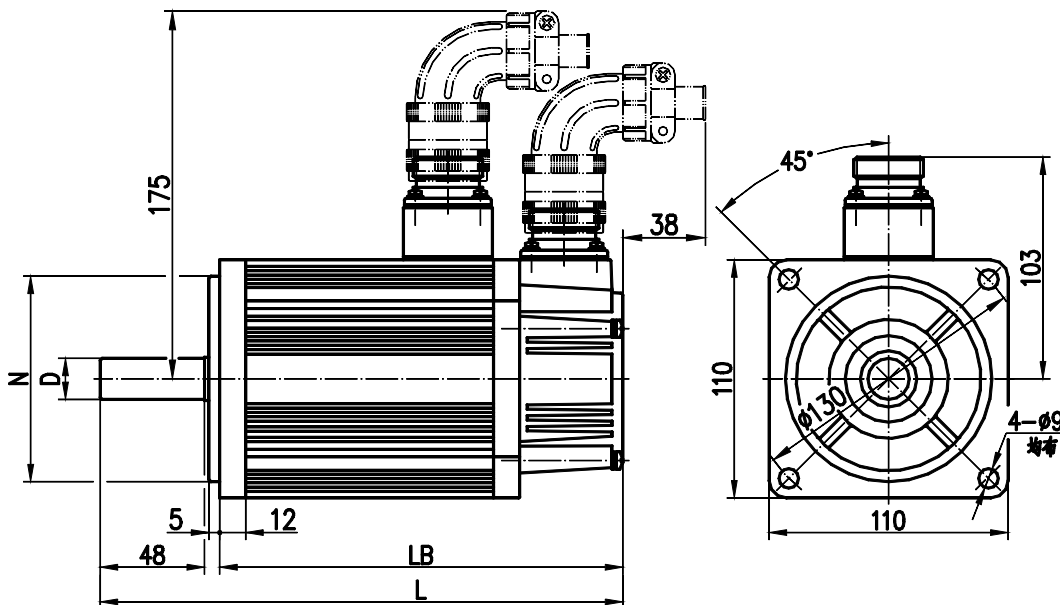

Type	D (mm)	N (mm)	LB (mm)	L (mm)
110SJT-M040D	$\phi 19^{0}_{-0.013}$	$\phi 95^{0}_{-0.035}$	186 (237)	241 (292)
110SJT-M060D	$\phi 19^{0}_{-0.013}$	$\phi 95^{0}_{-0.035}$	212 (263)	267 (318)

Remark: LB and L values of motor with brake are included in the brackets.

CNCmakers Limited

Address: No.168, Xiadu Road, Haizhu District, Guangzhou, China 510300

Email: info@CNCmakers.com

Website: www.CNCmakers.com

Tel: +86-138-24444158

Fax: +86-20-84185336

130SJT SERIES MOTOR OUTLINE DIMENSION:

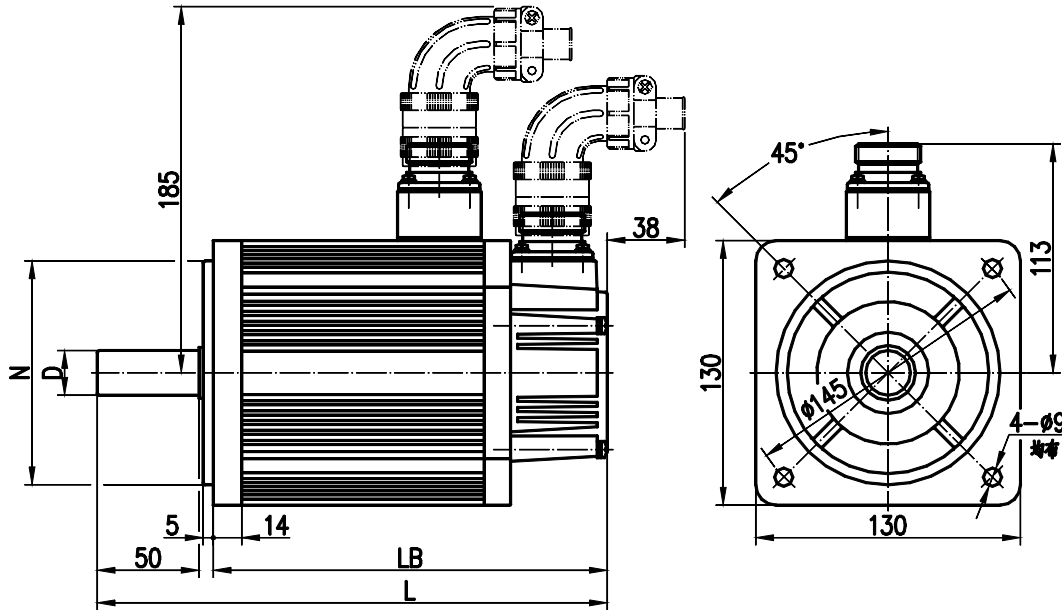

Type	D (mm)	N (mm)	LB (mm)	L (mm)
130SJT-M040D	$\phi 22^{0}_{-0.013}$	$\phi 110^{0}_{-0.035}$	168 (227)	225 (284)
130SJT-M050D	$\phi 22^{0}_{-0.013}$	$\phi 110^{0}_{-0.035}$	168 (227)	225 (284)
130SJT-M060D	$\phi 22^{0}_{-0.013}$	$\phi 110^{0}_{-0.035}$	176 (235)	233 (292)
130SJT-M075D	$\phi 22^{0}_{-0.013}$	$\phi 110^{0}_{-0.035}$	188 (247)	245 (304)
130SJT-M100B	$\phi 22^{0}_{-0.013}$	$\phi 110^{0}_{-0.035}$	208 (267)	265 (324)
130SJT-M100D	$\phi 22^{0}_{-0.013}$	$\phi 110^{0}_{-0.035}$	208 (267)	265 (324)
130SJT-M150B	$\phi 22^{0}_{-0.013}$	$\phi 110^{0}_{-0.035}$	238 (297)	295 (354)
130SJT-M150D	$\phi 22^{0}_{-0.013}$	$\phi 110^{0}_{-0.035}$	248 (307)	305 (364)

Remark: LB and L values of motor with brake are included in the brackets.

CNCmakers Limited

Address: No.168, Xiadu Road, Haizhu District, Guangzhou, China 510300

Email: info@CNCmakers.com Website: www.CNCmakers.com Tel: +86-138-24444158 Fax: +86-20-84185336

175SJT SERIES MOTOR OUTLINE DIMENSION:

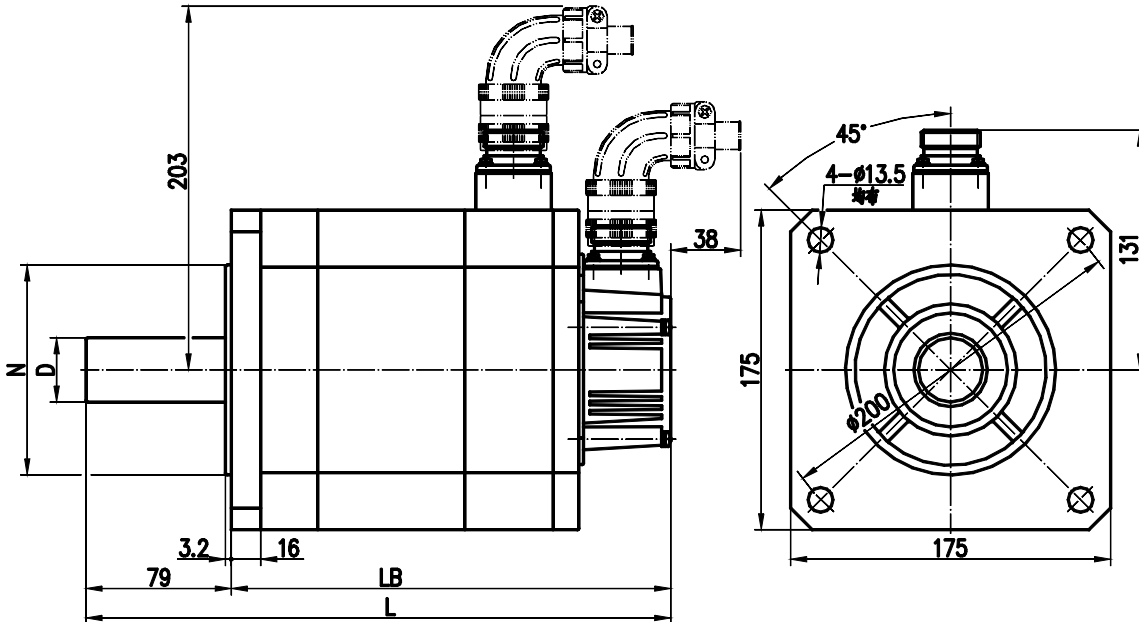

Type	D(mm)	N(mm)	LB(mm)	L(mm)
175SJT-M180B	$\phi 35_0^{+0.01}$	$\phi 114.3_0^{-0.025}$	244 (311)	323 (390)
175SJT-M180D	$\phi 35_0^{+0.01}$	$\phi 114.3_0^{-0.025}$	244 (311)	323 (390)
175SJT-M220B	$\phi 35_0^{+0.01}$	$\phi 114.3_0^{-0.025}$	279 (346)	358 (425)
175SJT-M220D	$\phi 35_0^{+0.01}$	$\phi 114.3_0^{-0.025}$	279 (346)	358 (425)
175SJT-M300B	$\phi 35_0^{+0.01}$	$\phi 114.3_0^{-0.025}$	309 (382)	388 (461)
175SJT-M300D	$\phi 35_0^{+0.01}$	$\phi 114.3_0^{-0.025}$	309 (382)	388 (461)

Remark: LB and L values of motor with brake are included in the brackets.

Motor Mechanical Characteristic Curve

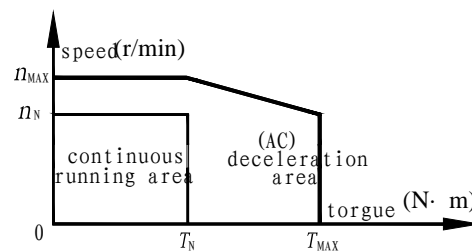

T_N ——— rated torque ; T_{MAX} ——— Max. torque ;
 n_N ——— rated speed ; n_{MAX} ——— Max speed